

Diaphragm monitoring system

For sanitary applications

Model DMS-FP

WIKA data sheet DS 95.20



Applications

- Hygienic pressure measurement for the pharmaceutical industry and for aseptic food processing
- Pressure/vacuum monitoring on pipelines, fermenters, bioreactors and vessels as well as with processing and transport of high-quality and critical media
- Suitable for the production of active pharmaceutical ingredients (API)
- For gases, vapour; liquid, pasty, powdery and crystallising media

Special features

- Double-diaphragm system to ensure the separation of the process and the pressure measuring instrument
- Clamp connection easy to open for cleaning and seal replacement
- Suitable for SIP and CIP
- Patent applied for in various countries, e.g. DE 19 94 98 31

Description

The WIKA combinations of diaphragm seals, pressure measuring instruments and monitoring instruments are best suited for the harshest and hygienic measuring tasks. The systems can withstand the cleaning-vapour temperatures occurring in SIP processes and ensure a sterile connection between the medium and the diaphragm seal.

Patented diaphragm monitoring has been designed specifically for the highest safety requirements in the pharmaceutical and biotechnology industries. Through the diaphragm monitoring, the risk of an unnoticed rupture of the diaphragm is avoided, since this is immediately indicated on the monitoring instrument. In addition, an electrical signal can be transmitted to the system control. In the event of a diaphragm rupture, a second diaphragm in the pressure measuring instrument ensures the reliable separation of the environment and the process.



Diaphragm monitoring systems, model DMS-FP

Mounting of the diaphragm seal to the measuring instrument is made as direct mounting as standard. A fluid inside the system, which is explicitly chosen to suit the particular application, hydraulically transmits the pressure to the pressure measuring instrument.

Diaphragm seals with clamp connection have been specifically developed for use in sterile processes and are integrated into the process by means of a clamp. This ensures the hygienic process integration of the diaphragm monitoring system.

The diaphragm seal systems with WIKA diaphragm seals are successfully used in the life science industry, in food production, pharmaceutical and biotechnology applications.

Illustrative example of a diaphragm monitoring system

The diaphragm monitoring system is a combination of pressure measuring instrument, diaphragm seal and monitoring instrument.

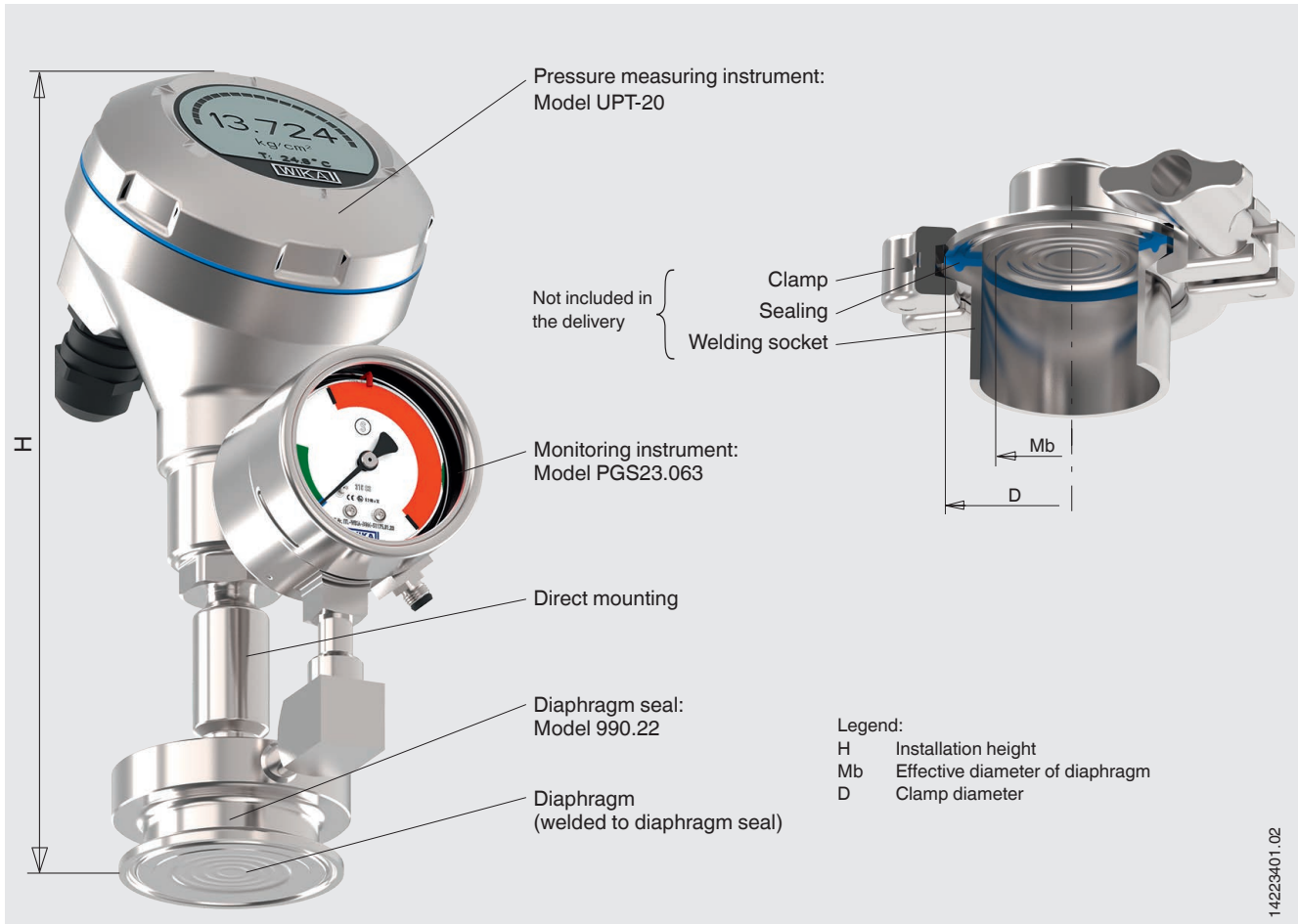

Functional principle of diaphragm monitoring diaphragm seal typ 990.22

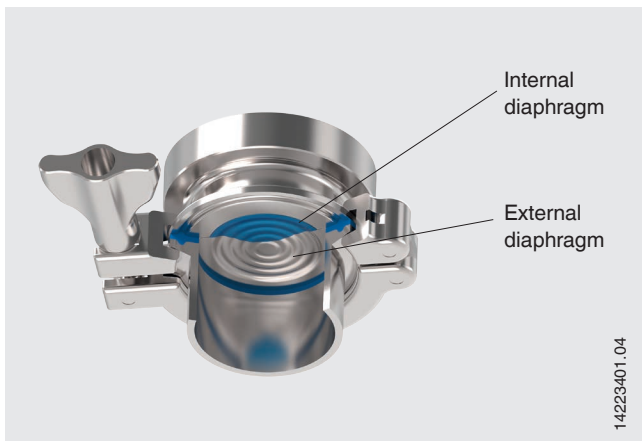

WIKA's patented double-diaphragm design (patent no. DE19949831) is the solution for critical processes where neither the medium should find its way into the environment, nor should the system fill fluid find its way into the product.

The space between the two diaphragms illustrated is evacuated. The vacuum that is generated by this is monitored by the monitoring instrument.

Should a diaphragm rupture, there will be an optical or electrical warning through the selected monitoring instrument.

Specifications

Diaphragm seal system				
Design	Pressure measuring instrument mounted to a diaphragm seal with clamp connection, welded			
Scale range	0 ... 2.5 (0 ... 40)	0 ... 4 (0 ... 60)	0 ... 6 (0 ... 1,000)	0 ... 10 (0 ... 150)
Gauge pressure in bar (psi)	0 ... 16 (0 ... 250)	0 ... 25 (0 ... 400)	0 ... 40 (0 ... 600)	
Scale range ¹⁾	-1 ... 1.6 (-30 inHg ... 25)	-1 ... 3 (-30 inHg ... 45)	-1 ... +5 (-30 inHg ... +70)	
Vacuum in bar (psi)	-1 ... 10 (-30 inHg ... 145)	-1 ... 15 (-30 inHg ... 220)	-15 ... 25 (-30 inHg ... 360)	
Permissible temperature range				
Medium	+10 ... +80 °C (+50 ... +176 °F) for SIP and CIP max. +130 °C (+266 °F)			
Ambient	+10 ... +40 °C (+50 ... +104 °F)			
Storage	+10 ... +60 °C (+50 ... +140 °F)			
Ingress protection per IEC/EN 60529	IP65			
Material ²⁾				
wetted	Diaphragm: Stainless steel 1.4435 (316L); UNS S31603 Upper body of diaphragm seal: Stainless steel 1.4435 (316L); UNS S31603			
Surface roughness				
wetted	Ra ≤ 0.38 µm (30 µin) per ASME BPE SF3, electropolished (except for weld seam)			
non-wetted	Ra ≤ 0.76 µm (30 µin) (except for weld seam)			
Mounting type	Direct mounting			
Level of cleanliness of wetted parts	Oil and grease free per ASTM G93-03 level E (WIKA standard) and ISO 15001 (< 1,000 mg/m ²)			
System fill fluid	Medicinal white mineral oil KN 92 (FDA 21 CFR 172.878, 21 CFR 178.3620(a); USP, EP, JP) Recommendation for pharmaceutical and cosmetics applications			

1) Under vacuum, the diaphragm monitoring function is only possible to a limited extent
2) Other materials on request

Operational safety with vacuum

Pressure measuring instruments with vacuum scale ranges are generally suitable for use with full vacuum.

Display behaviour for vacuum

The monitoring instrument is dependent upon the process pressure and can detect the diaphragm rupture up to a maximum of 250 mbar abs.

Specifications, monitoring instrument

Monitoring instrument	Model PGS23.063	Model 232.30.063
Design 1)	Pressure gauge with switch contact (safety version)	Pressure gauge (safety version)
Nominal size	63	
Material	Stainless steel, with solid baffle wall (Solidfront) and blow-out back	
Case	Stainless steel 316L	
Pressure element	Stainless steel	
Movement/bayonet ring	Aluminium	
Pointer/dial	Laminated safety glass	
Window		
Ingress protection per IEC/EN 60529	IP65	IP54
Pressure limitation	Steady: 3/4 x full scale value Short time: Full scale value Fluctuating: 2/3 x full scale value	
Electrical connection	Cable bushing with 2 m cable (optional connectors on request)	-
Reed switch model 851	No control unit and no power supply required Direct switching up to 150 V, 0.5 A Also suitable for direct triggering of a programmable logic controller (PLC) Free from wear as without contact	-

1) Recommendation: Model PGS23.063, since the electrical switch contact can be used for external alarm devices

Functional description

Diaphragm monitoring system is fully functional

Diaphragm monitoring system must be replaced



Process pressure

Should a diaphragm rupture occur, the full process pressure acts on the monitoring instrument. In the event of a diaphragm rupture, the monitoring instrument must therefore be designed for this process pressure.

Temperatures

The same process conditions apply to the monitoring instrument as to the pressure measuring instrument. The permissible temperature ranges for the monitoring instruments must be checked in the corresponding data sheet.

Medium

In the event of a diaphragm rupture, the measuring system of the monitoring instrument comes into contact with the medium. The measuring system must therefore be suitable for this medium.

Specifications, model DMS-FP with process transmitter model UPT-20

Model UPT-20	
Overload safety	Measuring range ≤ 16 bar (300 psi): 3 times Measuring range > 16 bar (300 psi): 2 times
Output signal	4 ... 20 mA
Load in Ω	$\leq (U_+ - U_{\min}) / 0.023$ A
Power supply	DC 12 ... 36 V
Accuracy specifications	0.10 % of span
Material	
Case	Stainless steel 316Ti
Sensor	Stainless steel 316L

Dimensions in mm (in)

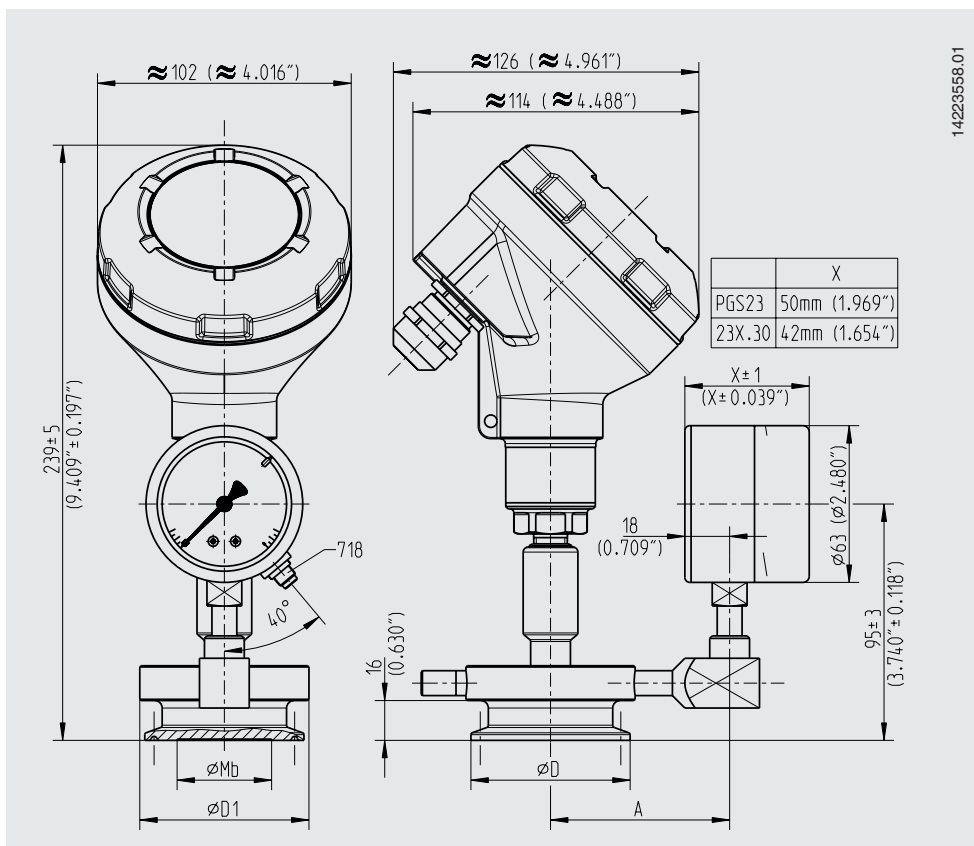

For further information see data sheet PE 86.05

Specifications, model DMS-FP with process transmitter model IPT-10

Model IPT-10	
Output signal	4 ... 20 mA (2-wire) 4 ... 20 mA (2-wire with a superimposed communication signal 4 HART®) FOUNDATION™ Fieldbus PROFIBUS® PA
Load in Ω	$(U_B - U_B) / 0.023 \text{ A}$
Accuracy at room temperature ¹⁾	Measuring ranges < 40 bar: $\leq 0.1 \%$ of span
Material	
Case	Single chamber case, stainless steel 316Ti
Sensor	Stainless steel 316L

1) Including non-linearity, hysteresis, zero offset and end value deviation (corresponds to measured error per IEC 61298-2). Calibrated in vertical mounting position with process connection facing downwards.

Dimensions in mm (in)

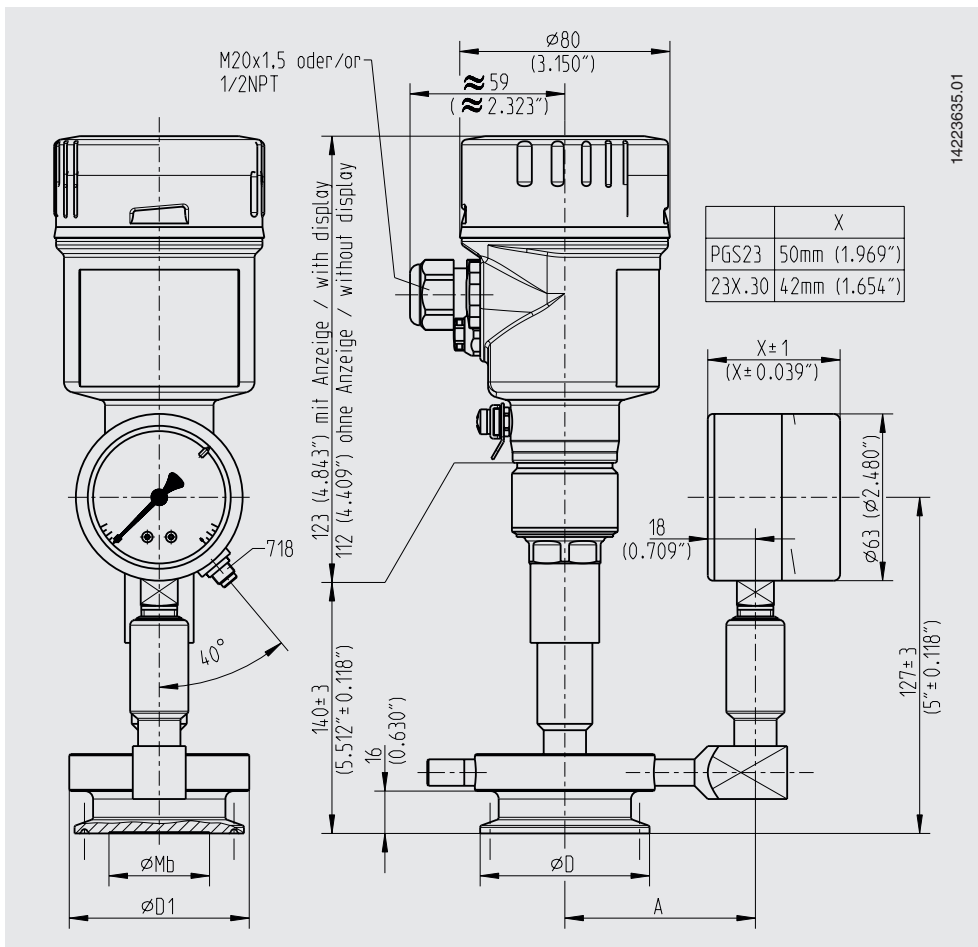

For further information see data sheet PE 86.11

Specifications, model DMS-FP with digital pressure gauge model CPG1500

Model CPG1500	
Overload safety	≤ 25 bar (≤ 300 psi); 3 times > 25 bar ≤ 600 bar (> 300 ... ≤ 5,000 psi); 2 times
Accuracy ¹⁾	0.1 % FS
Display	5 ½ digit 7-segment display (incl. a large matrix area for auxiliary information) Bar graph, 0 ... 100 % Selectable backlighting
Rotatable case	The case is rotatable by 330°
Resolution	4 ... 5 ½ digits; selectable
Voltage supply	
Power supply	3 x 1.5 V AA alkaline batteries ²⁾
Maximum voltage	DC 4.95 V (sparking)
Battery life	typical 2,000 ... 2,500 h (without backlighting and WIKA-Wireless not active)
Battery status display	Symbol display with 4 bars indicates the battery status in 25 % steps
Material	
Case	Aluminium die-casting, nickel-plated
Sensor	Stainless steel 316

1) It is defined by the total measurement uncertainty, which is expressed with the coverage factor (k = 2) and includes the following factors: the intrinsic performance of the instrument, the measurement uncertainty of the reference instrument, long-term stability, influence of ambient conditions, drift and temperature effects over the compensated range during a periodic zero point adjustment.

2) For hazardous areas, only the following models are permitted:

- Duracell, Simply by Duracell MN1500
- Duracell, Duralock Plus Power MN1500
- Varta, RAYOVAC Maximum Plus 4006

Dimensions in mm (in)

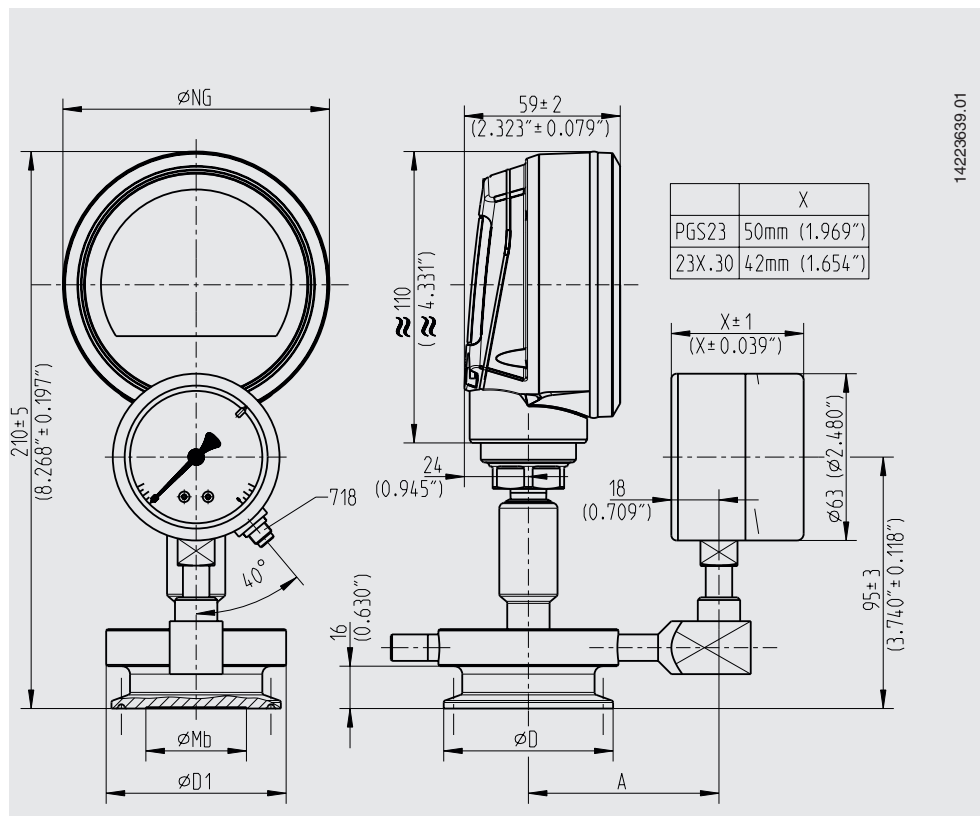

For further information see data sheet CT 10.51

Specifications, model DMS-FP with Bourdon tube pressure gauge model 23x.30.100

Model 23x.30.100	
Nominal size	100
Ingress protection per IEC/EN 60529	IP65
Pressure limitation	Steady: 3/4 x full scale value Fluctuating: 2/3 x full scale value Short time: Full scale value
Material	
Case	Stainless steel, with solid baffle wall (Solidfront) and blow-out back, scale ranges $\leq 0 \dots 16$ bar (lower mount) with compensating valve to vent case
Pressure element	Stainless steel 316L
Movement	Stainless steel 316L
Dial	Aluminium, white, black lettering
Pointer	Aluminium, black
Window	Laminated safety glass

Dimensions in mm (in)

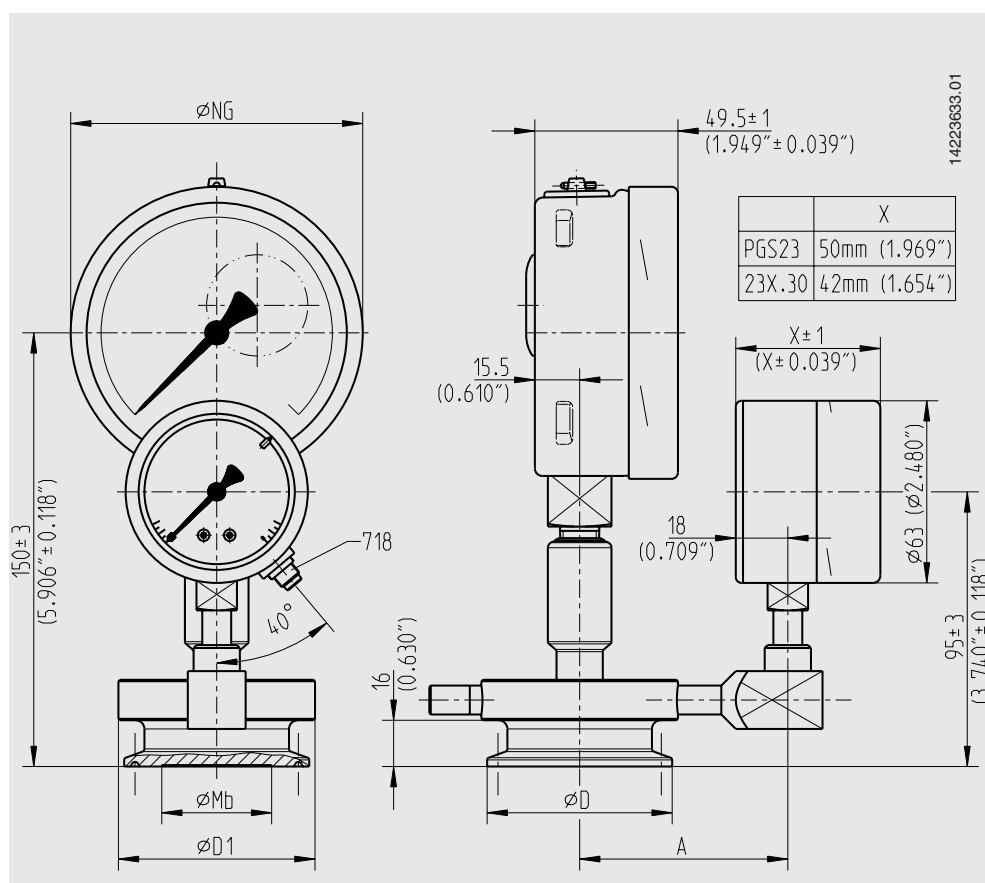

For further information see data sheet PM 02.04

Diaphragm seal model 990.22

Dimensions in mm (in)

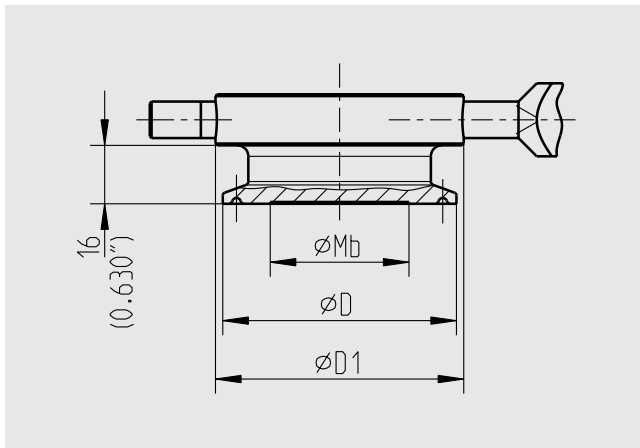

Type of process connection: Clamp connection per DIN 32676

Pipe standard: Pipes per DIN 11866 row C or ASME BPE

DN	For outer \varnothing of pipe x wall thickness	PN ¹⁾	D	D1	Mb	A
1 1/2"	38.1 x 1.65 (1.5 x 0.065)	40	50.5 (1.988)	58 (2.283)	32 (1.26)	67 (2.638)
2"	50.8 x 1.65 (2 x 0.065)		64 (2.52)	68 (2.677)	40 (1.574)	72 (2.835)

Type of process connection: Clamp connection per DIN 32676

Pipe standard: Pipes per DIN 11866 row B or ISO 1127 row 1

DN	For pip Outer \varnothing of pipe x wall thickness	PN ¹⁾	D	D1	Mb	A
1 1/2"	42.4 x 2 (1.67 x 0.079)	40	50.5 (1.988)	58 (2.283)	32 (1.26)	67 (2.638)
2"	48.3 x 2 (1.901 x 0.079)		64 (2.52)	68 (2.677)	40 (1.574)	72 (2.835)

Type of process connection: Clamp connection

Pipe standard: Pipes per BS4825 part 3 and O.D. tube

DN	For pipe Outer \varnothing of pipe x wall thickness	PN ¹⁾	D	D1	Mb	A
1 1/2"	38.1 x 1.6 (1.5 x 0.062)	40	50.5 (1.988)	58 (2.283)	32 (1.26)	67 (2.638)
2"	50.8 x 1.6 (2 x 0.062)		64 (2.52)	68 (2.677)	40 (1.574)	72 (2.835)

1) For maximum pressure range consider pressure rating of clamp.

Diaphragm seal model 990.52 and model 990.53

Dimensions in mm (in)

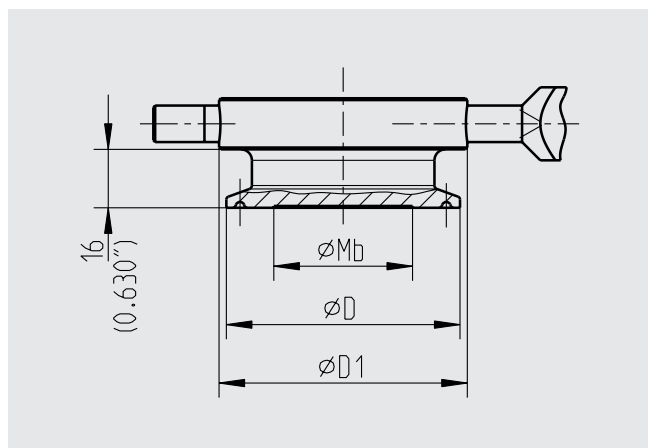

Diaphragm seal model 990.52

Type of process connection: Clamp connection per DIN 32676

Pipe standard: Pipes per DIN 11866 row A or DIN 11850 row 2

DN	For pipe Outer \varnothing of pipe x wall thickness	PN ¹⁾	D	D1	Mb	A
40	41 x 1.5 (1.614 x 0.06)	40	50.5 (1.988)	58 (2.283)	32 (1.26)	67 (2.638)
50	53 x 1.5 (2.087 x 0.06)		64 (2.52)	68 (2.677)	40 (1.574)	72 (2.835)

Diaphragm seal model 990.53



Type of process connection: Clamp connection per ISO 2852

Pipe standard: Pipes per ISO 2037 and BS 4825 part 1

DN	For pipe Outer \varnothing of x wall thickness	PN ¹⁾	D	D1	Mb	A
38	38 x 1.2 (1.5 x 0.047)	40	50.5 (1.988)	58 (2.283)	32 (1.26)	67 (2.638)
40	40 x 1.2 (1.745 x 0.047)					67 (2.638)
50	51 x 1.2 (2.008 x 0.047)		64 (2.52)	68 (2.677)	40 (1.574)	72 (2.835)

1) For maximum pressure range consider pressure rating of clamp.

Approvals

Logo	Description	Country
	3-A Sanitary Standard These instruments are optionally 3-A marked based on a third party verification for conformance to the 3-A standard number 74.	USA
	EHEDG Hygienic Equipment Design	European Union

Certificates (option)

- 2.2 test report per EN 10204
(e.g. surface finish quality of wetted parts)
- 3.1 inspection certificate per EN 10204
(e.g. material proof, wetted metallic parts with suppliers' certificate (melting analysis), measurement accuracy: Listing of the single measured values)
- Others on request

Patents, property rights

- Diaphragm monitoring system registered under no. DE 19 94 98 31
- Further patents have been applied for, e.g. DE 102016015447 A1, and in other countries, e.g. USA and China

Approvals and certificates, see website

© 05/2017 WIKA Alexander Wiegand SE & Co. KG, all rights reserved.
The specifications given in this document represent the state of engineering at the time of publishing.
We reserve the right to make modifications to the specifications and materials.

