

# Diaphragm monitoring system

## For the chemical and petrochemical industries

### Model DMS34

WIKA data sheet DS 95.18

#### Applications

- Suitable for applications with hydrofluoric acid content
- For aggressive, contaminated or hot media
- Pressure/vacuum monitoring on pipelines or transport of critical media
- Pressure measurement for the chemical/petrochemical sectors, oil/gas industries and water/wastewater plants-  
Pressure measurement for the chemical/petrochemical sectors, oil/gas industries and water/wastewater plants

#### Special features

- Double-diaphragm system to ensure the separation of the process and the pressure measuring instrument
- Process connection with thread to provide for direct threaded connection
- All welded design with internal diaphragm
- System entirely from Monel
- Patent applied for in various countries, e.g. DE 19 94 98 31



Diaphragm monitoring system, model DMS34

#### Description

The WIKA combination of diaphragm seal, pressure measuring instrument and monitoring instrument is ideally suited for the harshest measurement tasks. The system can withstand aggressive, contaminated or hot media and ensures a secure connection between the medium and the diaphragm monitoring system.

The patented diaphragm monitoring has been designed specifically for the highest safety requirements in the chemical and petrochemical industries. Through the diaphragm monitoring, the risk of an unnoticed rupture of the diaphragm is avoided, since this is immediately indicated on the monitoring instrument. In addition, an electrical signal can be transmitted to the system control.

In the event of a diaphragm rupture, a second diaphragm in the pressure measuring instrument ensures the reliable separation of the environment and the process.

Mounting of the diaphragm seal to the pressure measuring instrument is made as direct mounting as standard. A fluid inside the system, which is explicitly chosen to suit the particular application, hydraulically transmits the pressure to the pressure measuring instrument.

Diaphragm monitoring systems with the WIKA model 990.34 diaphragm seals are used successfully in applications with hydrofluoric acid content.

## Installation example of the diaphragm monitoring system

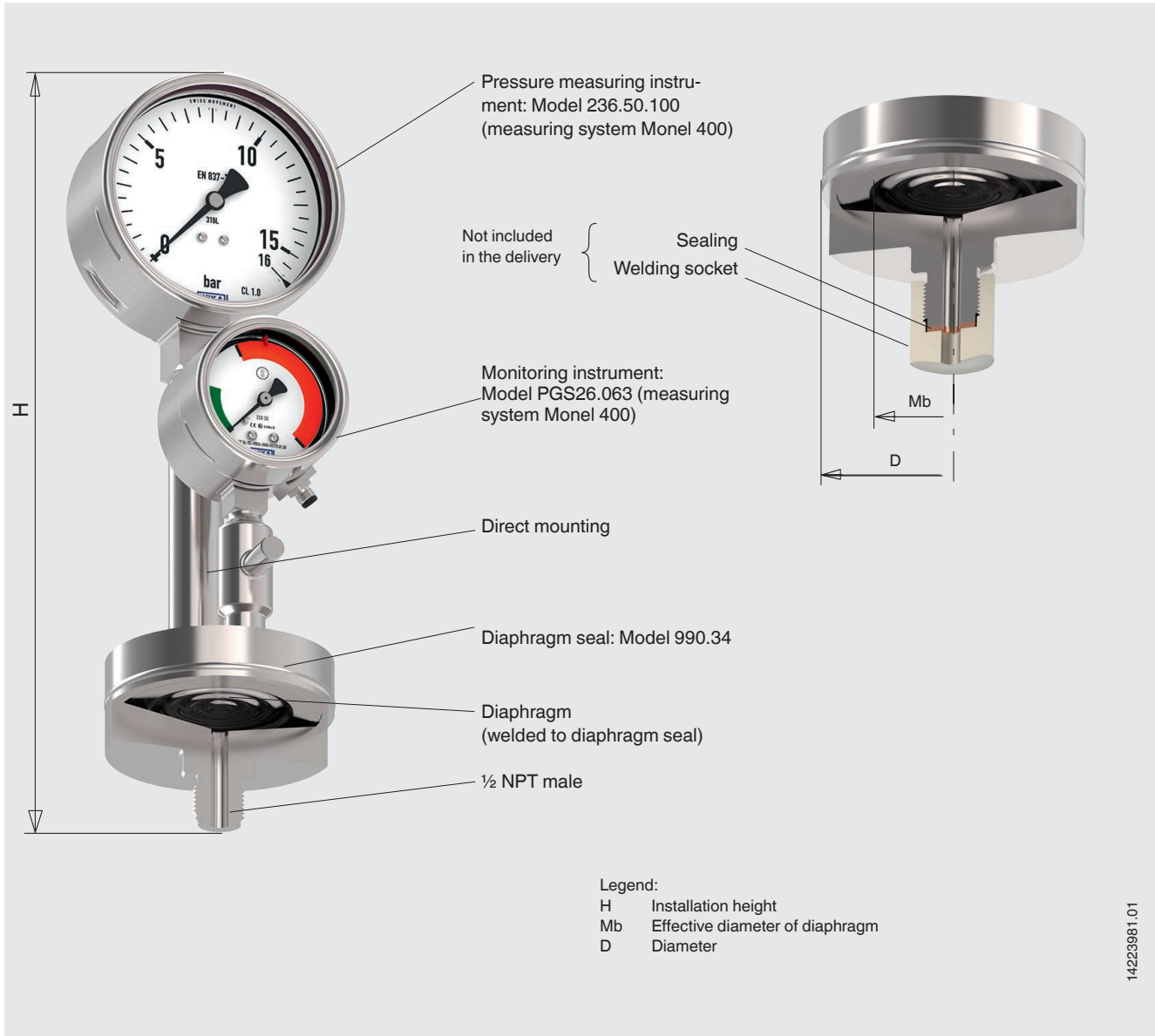

## Functional principle of diaphragm monitoring, diaphragm seal model 990.34

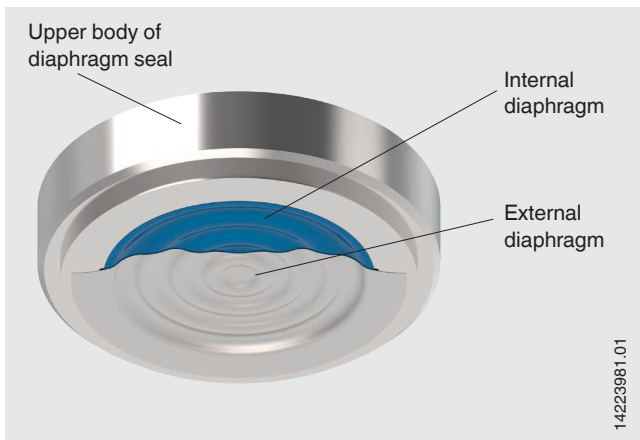

WIKA's patented double-diaphragm design (patent no. DE19949831) is the solution for critical processes where neither the medium should find its way into the environment, nor should the system fill fluid find its way into the product.

The space (shown in blue in the picture) between the two diaphragms illustrated is evacuated. As a result, in normal operation, the two diaphragms act as a single diaphragm and transfer the pressure from the medium to a system fill fluid behind it. This feeds the pressure through, hydraulically, to the pressure measuring instrument.

The vacuum between the two diaphragms is monitored by the monitoring instrument. Should a diaphragm rupture, the vacuum breaks immediately and there will be an optical or electrical warning through the selected monitoring instrument.

## Specifications

Diaphragm seal system				
<b>Design</b>	Pressure measuring instrument welded to diaphragm seal			
<b>Scale range</b>	0 ... 2.5 (0 ... 40)	0 ... 4 (0 ... 60)	0 ... 6 (0 ... 1,000)	0 ... 10 (0 ... 150)
<b>Gauge pressure in bar (psi)</b>	0 ... 16 (0 ... 250)	0 ... 25 (0 ... 400)	0 ... 40 (0 ... 600)	
<b>Scale range <sup>1)</sup></b>	-1 ... +1.6 (-30 inHg ... +25)	-1 ... +3 (-30 inHg ... +45)	-1 ... +5 (-30 inHg ... +70)	
<b>Vacuum in bar (psi)</b>	-1 ... +10 (-30 inHg ... +145)	-1 ... +15 (-30 inHg ... +220)	-1 ... +25 (-30 inHg ... +360)	
<b>Permissible temperature range</b>				
Medium	10 ... 150 °C (50 ... 302 °F)			
Ambient	10 ... 40 °C (50 ... 104 °F)			
Storage	10 ... 60 °C (50 ... 140 °F)			
<b>Ingress protection per IEC/EN 60529</b>	IP65			
<b>Materials <sup>2)</sup> wetted</b>	Diaphragm: Monel 400 2.4360; UNS 04400 Upper body of diaphragm seal: Monel 400 2.4360; UNS 04400			
<b>Mounting type</b>	Direct mounting			
<b>Level of cleanliness of wetted parts</b>	Oil and grease free per ASTM G93-03 level E (WIKA standard) and ISO 15001 (< 1,000 mg/m <sup>2</sup> )			
<b>System fill fluid</b>	KN 21 halocarbon			

1) Under vacuum, the diaphragm monitoring function is only possible to a limited extent

2) Other materials on request

### Operational safety with vacuum

Pressure measuring instruments with vacuum scale ranges are generally suitable for use with full vacuum.

### Display behaviour for vacuum

The monitoring instrument is dependent upon the process pressure and can detect the diaphragm rupture up to a maximum of 250 mbar abs.

## Specifications, diaphragm monitoring

Monitoring instrument	Model PGS23.063
<b>Design</b>	Pressure gauge with switch contact (safety version)
<b>Nominal size</b>	63
<b>Material</b>	Case/ bayonet ring: Stainless steel Pressure element: Monel 400 2.4360; UNS 04400 Movement: Stainless steel Adjustable pointer/dial: Aluminium Window: Laminated safety glass
<b>Ingress protection per IEC/EN 60529</b>	IP54
<b>Pressure limitation</b>	Steady: 3/4 x full scale value Fluctuating: 2/3 x full scale value Short time: Full scale value
<b>Electrical connection</b>	Cable bushing with 2 m cable (optional connectors available on request)
<b>Reed switch model 851</b>	No control unit and no power supply required Direct switching up to 150 V, 0.5 A Also suitable for direct triggering of a programmable logic controller (PLC) Free from wear as without contact

For further information see data sheet AC 08.01, electrical switch contacts

## Functional description

**Diaphragm monitoring system is fully functional**

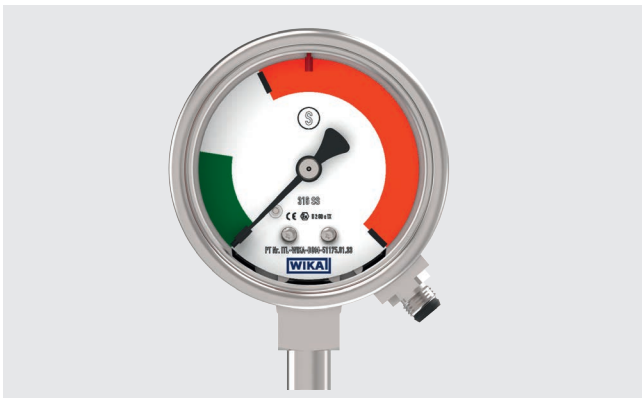

**Diaphragm monitoring system must be replaced**

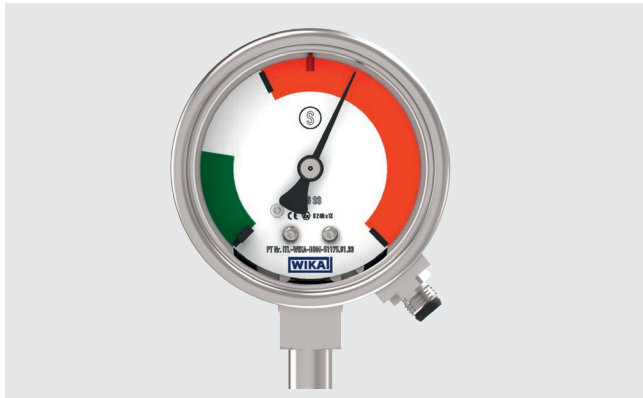

### Process pressure

Should a diaphragm rupture occur, the full process pressure acts on the monitoring instrument. In the event of a diaphragm rupture, the monitoring instrument must therefore be designed for this process pressure.

### Medium

In the event of a diaphragm rupture, the measuring system of the monitoring instrument comes into contact with the medium. The measuring system must therefore be suitable for this medium.

### Temperatures

The same process conditions apply to the monitoring instrument as to the pressure measuring instrument.

# Specifications, model DMS34 with model 262.30.100 pressure measuring instrument

Model 262.30.100 per EN 837-1	
<b>Nominal size</b>	100
<b>Pressure limitation</b>	Steady: 3/4 x full scale value Fluctuating: 2/3 x full scale value Short time: Full scale value
<b>Material</b>	Case/ bayonet ring: Stainless steel 316L Pressure element: Monel Movement: Stainless steel 316L Dial: Aluminium, white, black lettering Adjustable pointer: Aluminium, black Window: Laminated safety glass
<b>Ingress protection per IEC/EN 60529</b>	IP65

For further information see data sheet PM 02.02

## Dimensions in mm (in)

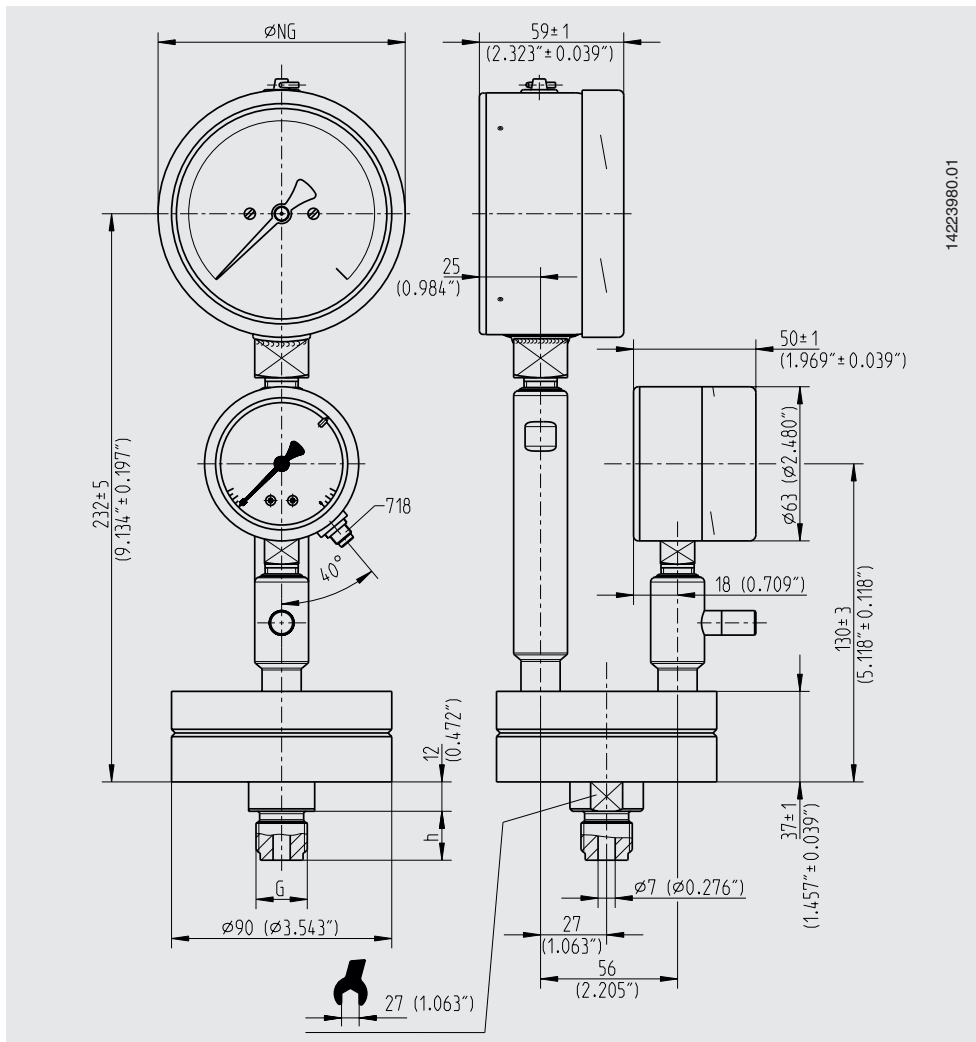

## Diaphragm seal model 990.34

Type of process connection: 1/2 NPT male

DN	PN	Mb	D
72	40	52 (2.047)	45 (1.772)

## Certificates (option)

- 2.2 test report per EN 10204  
(e.g. surface finish quality of wetted parts)
- 2.2 certification per Nace MR 1705 and MR 103
- 3.1 inspection certificate per EN 10204  
(e.g. material proof, wetted metallic parts with suppliers' certificate (melting analysis), measurement accuracy: Listing of the single measured values)
- Others on request

## Patents, property rights

- Diaphragm monitoring for diaphragm seals, registered under no. DE 19 94 98 31
- Further patents have been applied for, e.g. DE 102016015447 A1, and also in other countries, e.g. USA and China

Approvals and certificates, see website

