

Digital indicator for panel mounting

Model DI15

WIKA data sheet AC 80.01

Applications

- Plant construction
- Machine tools
- Test benches
- General industrial applications

Special features

- Multi-function input for resistance thermometers, thermocouples and standard signals
- 2 transistor switching outputs: output type (NPN, PNP, Push-Pull) freely selectable
- High measuring rate for standard signals
- Compact design: 48 x 24 x 65 mm



Digital indicator model DI15

Description

The model DI15 digital indicator, through the multitude of connectable input signals and the compact design, can be used in the widest range of applications.

The concept of this universal digital indicator enables easy adaptation to the respective measurement tasks, on site and without any other tools. The selection of the input signal is made via the connection to the instrument terminals and by setting in the menu. The scaling of the indication range and the switching outputs is made via the front keys. A logically-structured menu guides the operator through all the necessary programming steps using simple characters on the LED panel.

Two freely-programmable transistor switching outputs, with independently settable hysteresis, are standard with the digital indicator. The digital signal processing ensures a precise switching of the limit values. The response time is adjustable from 0 to 99 minutes.

An EASYBUS serial interface for the transmission of measurement data is available as standard.

The fitting time is reduced to a minimum through the stainless steel spring clip. The display can be mounted easily in control panels of up to 10 mm thickness. Through the compact design, even use in applications with limited mounting space is possible.

Specifications

Digital indicator model DI15

Digital indicator		
Display		
Principle	7-segment LED, 4-digit, red	
Character size	10 mm	
Indication range	-1999 ... 9999	
Input		
Number and type	1 multi-function input for resistance thermometers, thermocouples and standard signals	
Current signals	0 ... 20 mA, 4 ... 20 mA	Input impedance ~125 Ω
Voltage signals	DC 0 ... 50 mV, DC 0 ... 1 V, DC 0 ... 2 V	Input impedance ≥ 10 kΩ
	DC 0 ... 10 V	Input impedance ≥ 300 kΩ
Thermocouples	Type K, S, N, J, T	
Resistance thermometers	Pt100 3-wire, Pt1000 2-wire	max. permissible resistance per connection line: 20 Ω
Measuring rate	approx. 4/s for temperature sensors, approx. 100/s for standard signals	
Input configuration	Selectable via terminal connections and menu-driven programming	
Alarm outputs		
Number and type	2 switching outputs, not galvanically isolated	
Type of output	adjustable: Low-side (NPN, "ground switching") High-side (PNP, "+Uv-switching") Push-Pull (switching between ground GND and power supply +Uv)	
Connection data	Low-side: 28 V, 1 A High-side: Uv, 200 mA	
Output functions	2-point, 3-point, 2-point with alarm, Min-/Max alarm joint or separated	
Switch points	freely selectable	
Voltage supply		
Power supply	DC 9 ... 28 V	
Current consumption	max. 30 mA (without switching output and interface)	
Electrical connection	removable screw terminals 2-pin for interface, 9-pin for all other connections Conductor cross section from 0.14 mm ² ... 1.5 mm ²	
Communication		
Interface	EASYBUS, galvanically isolated	

Case	
Material	glass-fibre reinforced Noryl, window: polycarbonate
Colour	black, window: red
Ingress protection	Front: IP 54; IP 65 using the O-rings delivered with it Rear: IP 00
Dimensions	48 x 24 x 65 mm
Panel cutout	45 x 21.7 mm
Weight	approx. 50 g
Mounting	Stainless steel spring clip for wall thicknesses from 1 ... 10 mm

Permissible ambient conditions	
Operating temperature	-20 ... +50 °C
Storage temperature	-30 ... +70 °C
Relative humidity	0 ... 80 % r.h. mean annual relative humidity, non-condensing

CE conformity	
EMC directive	2004/108/EC, EN 61326 emission (group 1, class A) and interference immunity (industrial application)

Input signals	Measuring span		Measuring error in % of the span
Current signals	0 ... 20 mA		±0.2 % ±1 digit
	4 ... 20 mA		±0.2 % ±1 digit
Voltage signals	DC 0 ... 50 mV		±0.3 % ±1 digit
	DC 0 ... 1 V		±0.2 % ±1 digit
	DC 0 ... 2 V		±0.2 % ±1 digit
	DC 0 ... 10 V		±0.2 % ±1 digit
Thermocouples			
Type K, NiCr-Ni	-270 ... +1,350 °C	-454 ... +2,562 °F	±0.3 % ±1 digit
Type J, Fe-CuNi	-170 ... +950 °C	-274 ... +1,742 °F	±0.3 % ±1 digit
Type S, Pt10Rh-Pt	-50 ... +1,750 °C	-58 ... +3,182 °F	±0.5 % ±1 digit
Type T, Cu-CuNi	-270 ... +400 °C	-454 ... +752 °F	±0.3 % ±1 digit
Type N, NiCrSi-NiSi	-270 ... +1,300 °C	-454 ... +2,372 °F	±0.3 % ±1 digit
Resistance thermometers			
Pt100 (3-wire)	-50.0 ... +200.0 °C	-58.0 ... +392.0 °F	±0.5 % ±1 digit
	-200 ... +850 °C	-328 ... +1,562 °F	±0.5 % ±1 digit
Pt1000 (2-wire)	-200 ... +850 °C	-328 ... +1,562 °F	±0.5 % ±1 digit

Dimensions in mm

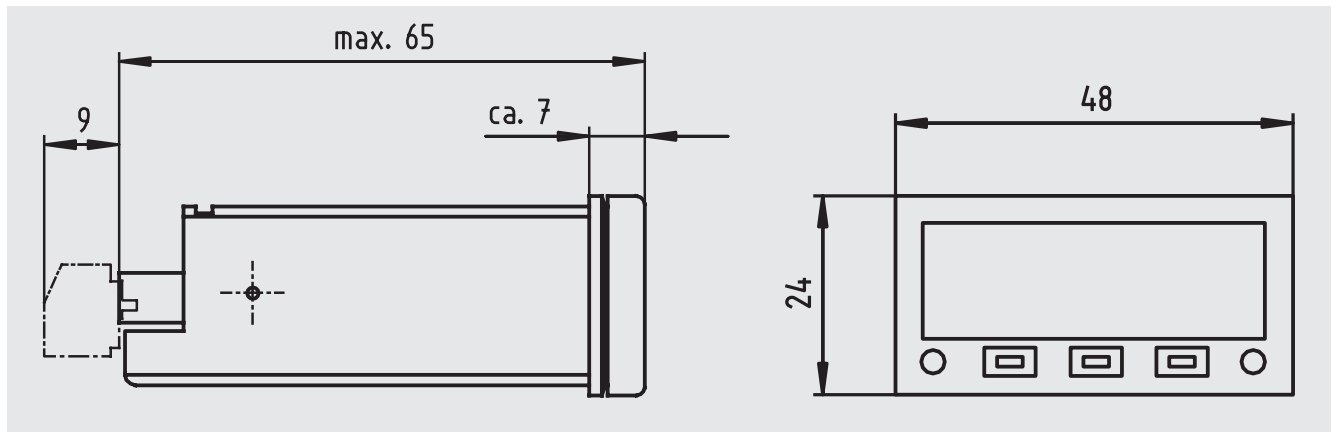

Panel cutout in mm

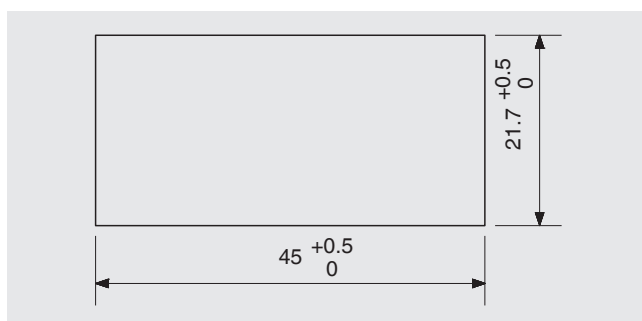

Terminal configuration

Terminal block	Description
1 Output 1	Switching output 1
2 Output 2	Switching output 2
3 GND	Switching output GND ¹⁾
4 Supply +Uv	Power supply +Uv
5 GND, Supply -Uv	Power supply GND ¹⁾
6 10 V	Input: DC 0 ... 10 V
7 GND, Pt100(0)	Input: GND, Pt100 (B), Pt1000 ¹⁾
8 mV, TC, Pt100	Input: DC 0 ... 50 mV, thermocouple (+), Pt100 (A)
9 1 V, mA, Freq., Pt100(0)	Input: DC 0 ... 1 V, DC 0 ... 2 V, 0(4) ... 20 mA, Frequency, Pt100 (B), Pt1000
10 EASYBUS	EASYBUS interface
11 EASYBUS	EASYBUS interface

1) Terminals 3, 5 and 7 are electrically connected within the instrument.

Scope of delivery

- Model DI15 digital indicator (Order no. 7464880)
- Two O-rings (sealings)
- Stainless steel spring clip
- Operating instructions

Ordering information

To order the described product the given order number is sufficient. Other options require additional specification.

© 2004 WIKA Alexander Wiegand SE & Co. KG, all rights reserved.
The specifications given in this document represent the state of engineering at the time of publishing.
We reserve the right to make modifications to the specifications and materials.

